

## Convection Oven Gas Convection Oven, 10 GN2/1 - 60Hz

ITEM # \_\_\_\_\_

MODEL # \_\_\_\_\_

NAME # \_\_\_\_\_

SIS # \_\_\_\_\_

AIA # \_\_\_\_\_



240478 (ZFCL12CSBQ)

Convection oven crosswise,  
10x2/1GN, gas - 60Hz - Q  
Mark

### Short Form Specification

**Item No.** \_\_\_\_\_

Convection oven with direct steam. Main structure in stainless steel. Cooking chamber with side lighting and drip tray. Double glass door. Heating via atmospheric burners with flame failure device. Main burner with pilot light and piezoelectric ignition. Electromechanical thermostat; temperature adjustable from 30°C to 300°C. Timer from 0 to 120 minutes with acoustic alarm. 5-level humidity control.

Q Mark approved.

Supplied with n. 1 "cross-wise" tray rack composed by 2 side hangers, 60 mm pitch, for 10x2/1GN grids.

### Main Features

- Main switch/Cooking mode selector which can be used to set: ON/OFF, hot air without humidification and hot air with humidification (choice of 5 different humidity levels).
- Rapid cooling of oven cavity.
- Timer to set the cooking time, adjustable up to 120 minutes or for continuous operation with an acoustic alarm to show the cycle has finished. At the end of the set cooking time the heat and the fan are automatically switched off.
- Maximum temperature of 300°C.
- Perfect evenness: guarantees perfect distribution of heat throughout the oven cavity.
- Halogen lighting and "crosswise" pan supports allow clear and unobstructed view of the products being cooked.
- Food temperature probe (available as accessory).
- Drip tray to collect residual cooking juices and fat.
- Drip tray under the door to collect condensed liquid available as accessory.
- Capacity: 10 GN 2/1 or 20 GN 1/1 trays.

### Construction

- Robust structure thanks to stainless steel construction.
- Cooking chamber in 430 AISI stainless steel.
- Double thermo-glazed door with open frame construction, for cool outside door panel. Swing hinged easy-release inner glass on door for easy cleaning.
- Ergonomic door handle.
- Integrated drain outlet.
- 1 pair of 60 mm pitch runners is supplied as standard.
- IPx4 water protection.
- Q Mark model delivered with nozzles for G30-50 mbar.

APPROVAL: \_\_\_\_\_

## Optional Accessories

- |   |            |                          |
|---|------------|--------------------------|
| • Pair of AISI 304 stainless steel grids, GN 1/1  | PNC 921101 | <input type="checkbox"/> |
| • Fat filter for gas 10 and 20 1/1 and 2/1 GN ovens (2 filters are necessary for 20-grid ovens)         | PNC 921700 | <input type="checkbox"/> |
| • Flue condenser for 10 1/1 and 2/1 GN gas ovens  | PNC 921701 | <input type="checkbox"/> |
| • Probe for 10 2/1 GN ovens   | PNC 921703 | <input type="checkbox"/> |
| • 1/1 GN drain pan guide kit  | PNC 921713 | <input type="checkbox"/> |
| • Pair of AISI 304 stainless steel grids, GN 1/1  | PNC 922017 | <input type="checkbox"/> |
| • Pair of grids for whole chicken (8 per grid - 1,2kg each), GN 1/1                                     | PNC 922036 | <input type="checkbox"/> |
| • AISI 304 stainless steel grid, GN 1/1   | PNC 922062 | <input type="checkbox"/> |
| • AISI 304 stainless steel grid, GN 2/1   | PNC 922076 | <input type="checkbox"/> |
| • Open base for 10 GN 2/1 convection oven   | PNC 922103 | <input type="checkbox"/> |
| • Shelf guides for 10 2/1 GN oven base  | PNC 922107 | <input type="checkbox"/> |
| • Feet for convection ovens 10 GN1/1 & 10 GN2/1   | PNC 922127 | <input type="checkbox"/> |
| • Trolley for 10 2/1 GN roll-in rack  | PNC 922128 | <input type="checkbox"/> |
| • Retractable hose reel water spray unit  | PNC 922170 | <input type="checkbox"/> |
| • External side spray unit (needs to be mounted outside and includes support to be mounted on the oven) | PNC 922171 | <input type="checkbox"/> |
| • Pair of baking tray support for 10 and 20 2/1 ovens   | PNC 922173 | <input type="checkbox"/> |
| • Pair of AISI 304 stainless steel grids, GN 2/1  | PNC 922175 | <input type="checkbox"/> |
| • Fat filter for 10 1/1 and 2/1 GN combi steamers (gas and electric) and convection ovens (electric)    | PNC 922178 | <input type="checkbox"/> |
| • Pair of frying baskets  | PNC 922239 | <input type="checkbox"/> |
| • Grid for whole chicken (8 per grid - 1,2kg each), GN 1/1  | PNC 922266 | <input type="checkbox"/> |
| • Kit universal skewer rack and 6 short skewers for Lengthwise GN 2/1 and Crosswise ovens               | PNC 922325 | <input type="checkbox"/> |
| • Universal skewer rack   | PNC 922326 | <input type="checkbox"/> |
| • 6 short skewers   | PNC 922328 | <input type="checkbox"/> |
| • Smoker for lengthwise and crosswise oven  | PNC 922338 | <input type="checkbox"/> |
| • Mesh grilling grid, GN 1/1  | PNC 922713 | <input type="checkbox"/> |
| • Non-stick universal pan, GN 1/1, H=20mm   | PNC 925000 | <input type="checkbox"/> |
| • Non-stick universal pan, GN 1/1, H=40mm   | PNC 925001 | <input type="checkbox"/> |
| • Non-stick universal pan, GN 1/1, H=60mm   | PNC 925002 | <input type="checkbox"/> |
| • Double-face griddle, one side ribbed and one side smooth, GN 1/1                                      | PNC 925003 | <input type="checkbox"/> |
| • Aluminum grill, GN 1/1  | PNC 925004 | <input type="checkbox"/> |
| • Frying pan for 8 eggs, pancakes, hamburgers, GN 1/1   | PNC 925005 | <input type="checkbox"/> |

**Front**

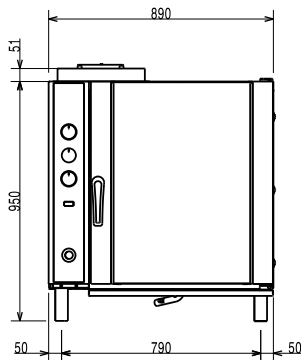

**Side**

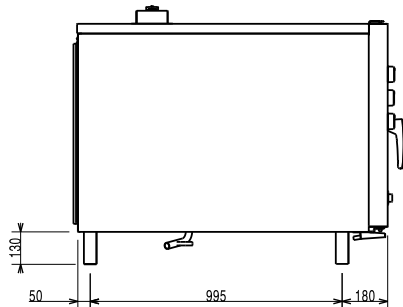

- CW11** = Cold Water inlet 1 (cleaning)
- CW12** = Cold Water Inlet 2 (steam generator)
- D** = Drain
- EI** = Electrical inlet (power)
- G** = Gas connection

**Top**

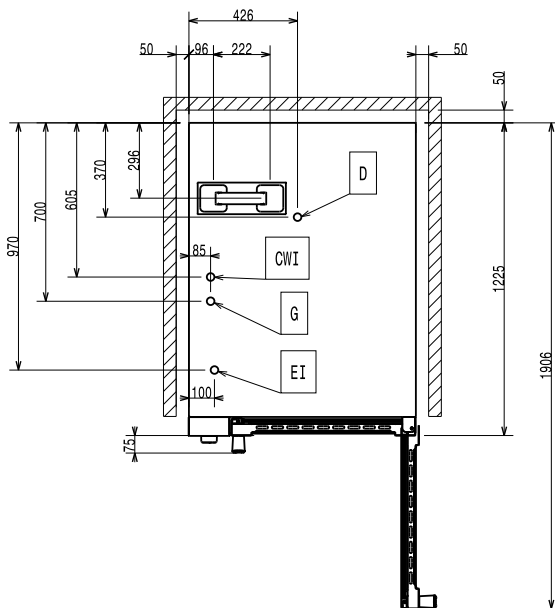

**Electric**

Supply voltage:	220-230 V/1 ph/60 Hz
Auxiliary:	0.5 kW
Electrical power, max:	0.5 kW

**Gas**

Gas Power:	25 kW
------------	-------

**Capacity:**

Trays type:	10 (GN 2/1)
Pitch:	60 mm
Shelf capacity:	10 Grids

**Key Information:**

External dimensions, Width:	890 mm
External dimensions, Depth:	1215 mm
External dimensions, Height:	970 mm
Net weight:	154 kg
Height adjustment:	80/0 mm
Functional level:	Basic
Cooking cycles - air-convection:	300 °C